

ADA ACCESSIBILITY IMPROVEMENTS AT THE EL PASO COUNTY FAIRGROUNDS

INDEX

G-1	GENERAL AND INDEX
C-1	AREA 1
C-2	AREA 2
C-3	AREA 3
D-1	DETAIL SHEET 1
D-2	DETAIL SHEET 2

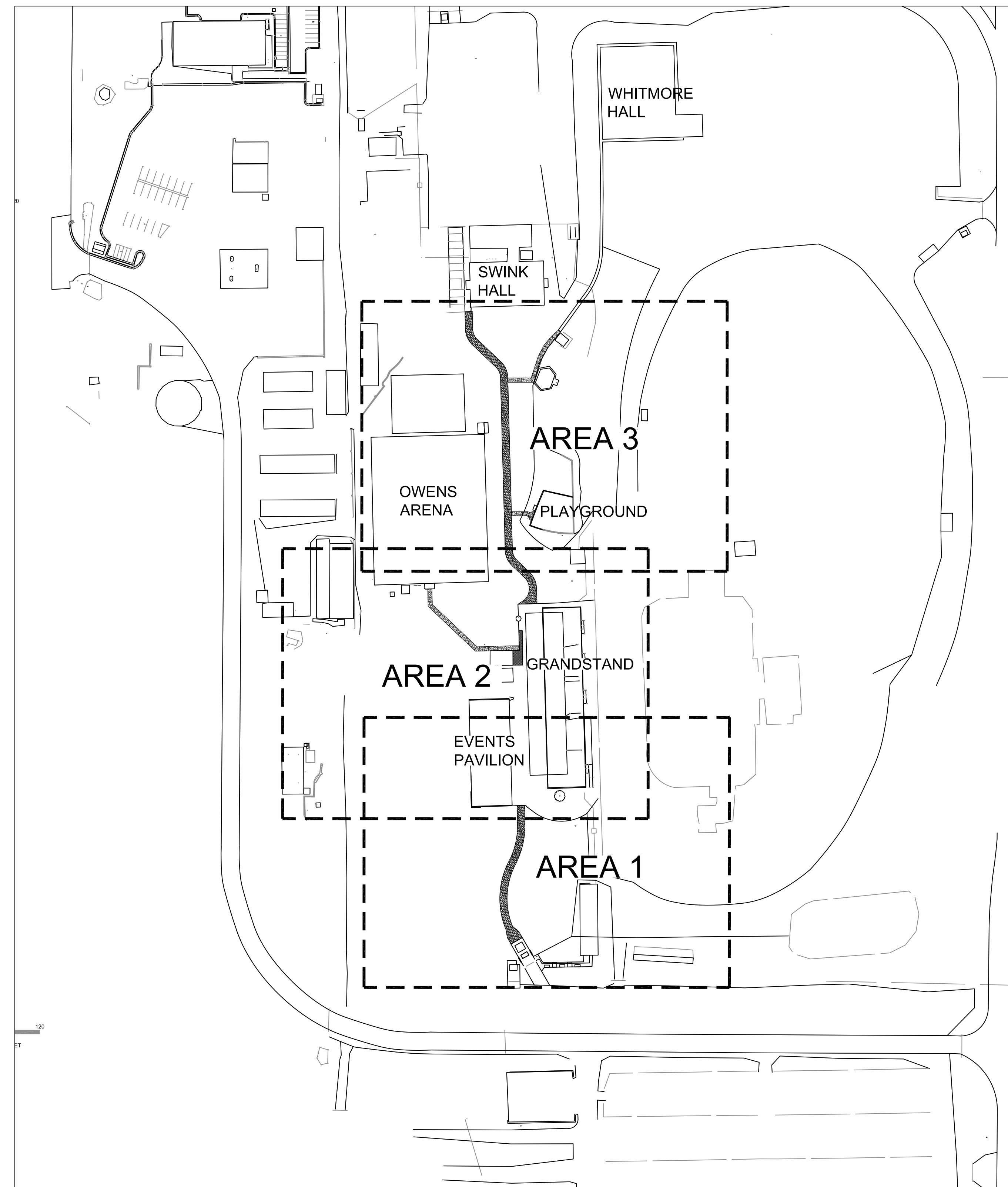
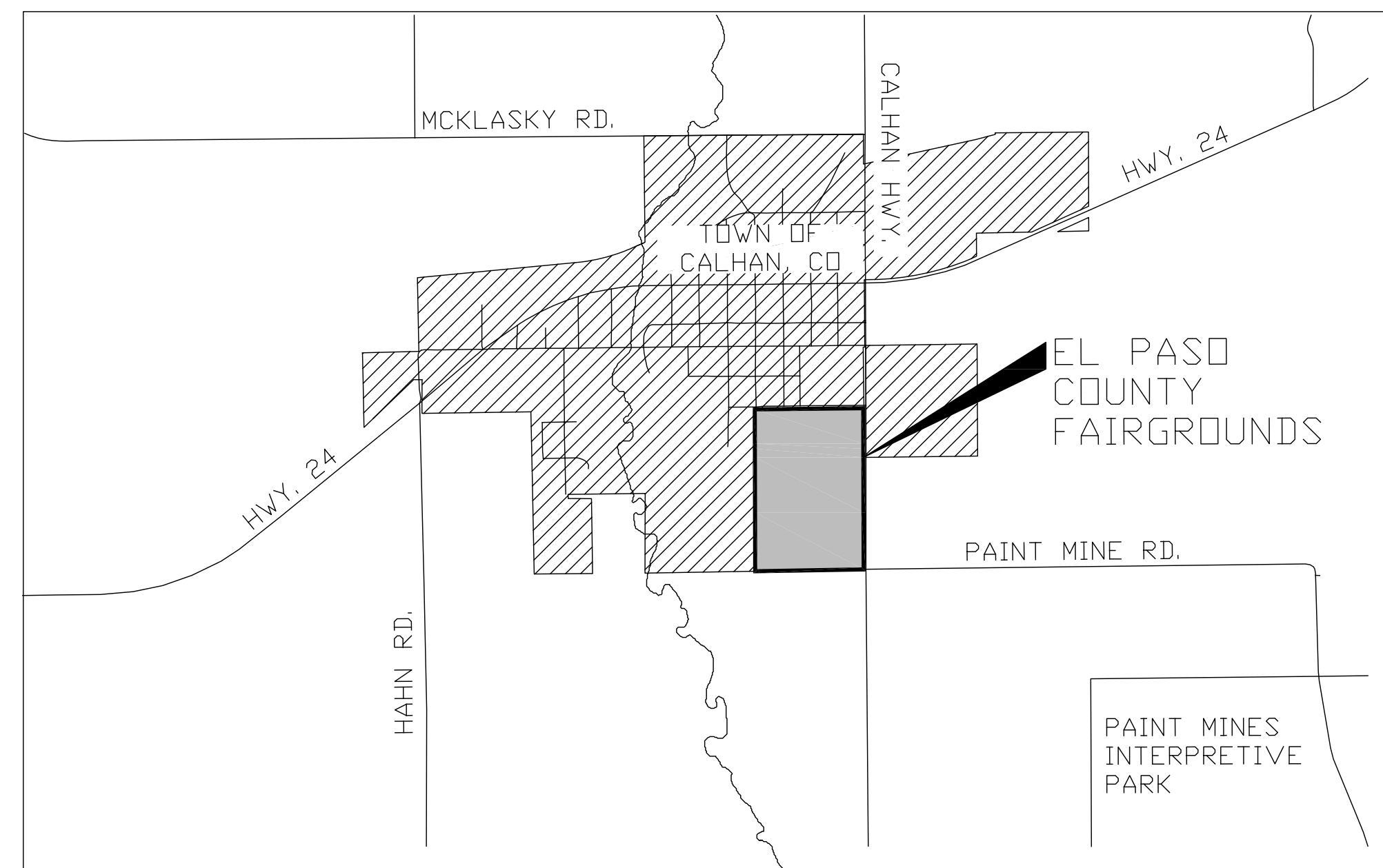

THIS DOCUMENT AND ITS CONTENTS ARE THE WORK PRODUCT AND EL PASO COUNTY PARKS WHICH RETAINS ALL COMMON LAW, STATUTORY AND OTHER RESERVED RIGHTS, INCLUDING THE COPYRIGHT.

General Notes

No.	Revision/Issue	Date

Firm Name and Address
EL PASO COUNTY PARKS
 2002 CREEK CROSSING
 COLORADO SPRINGS, CO 80905

Project Name and Address
ADA ACCESSIBILITY IMPROVEMENTS AT THE EL PASO COUNTY FAIRGROUNDS
 366 10TH STREET
 CALHAN, CO 80808

Project	Sheet
Date	G-1
03-04-2021	
Scale	1:100

1 ORIENTATION MAP

2 PLAN AREAS

FNAME

REVDATE

USER

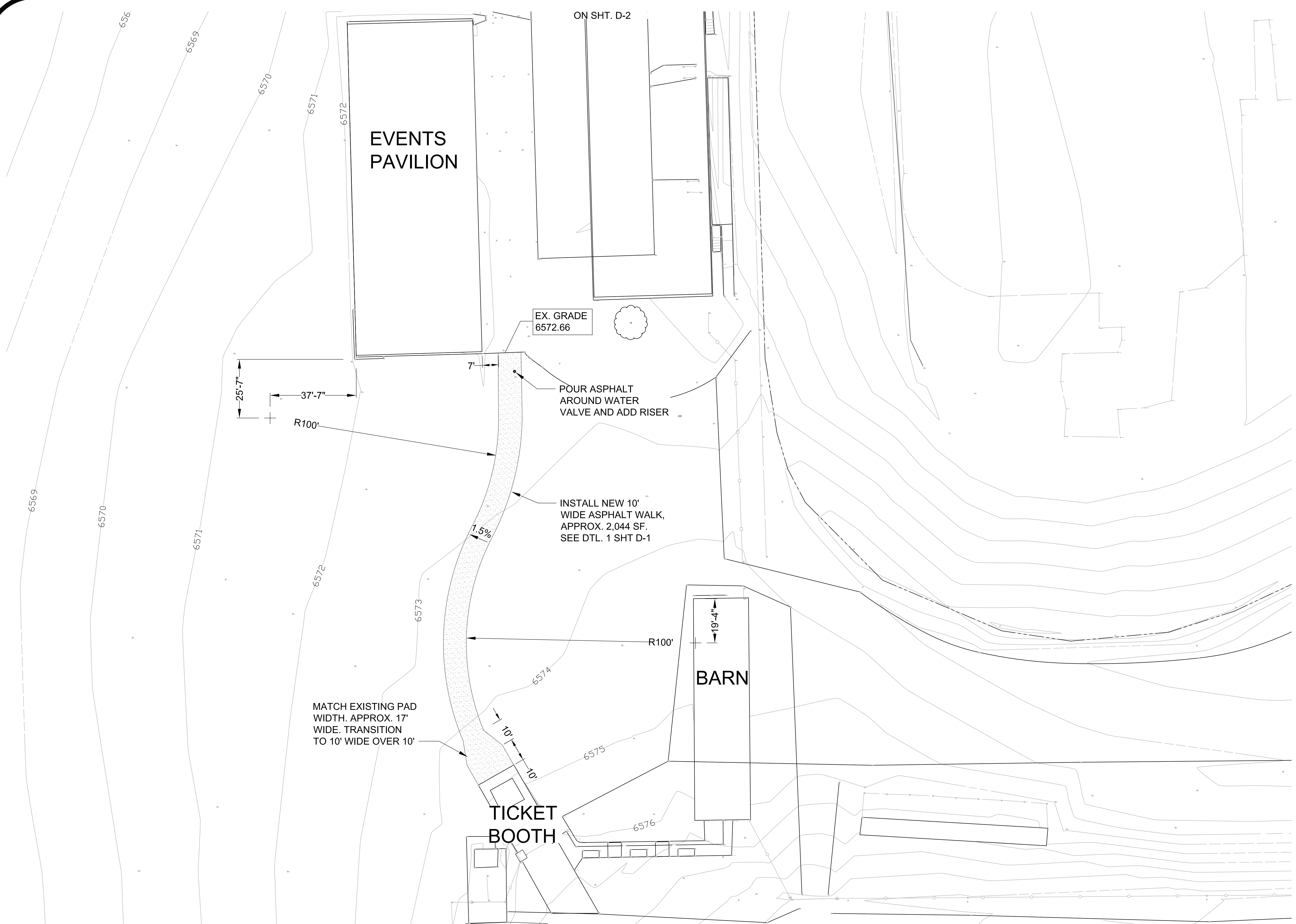

THIS DOCUMENT AND ITS CONTENTS ARE THE WORK PRODUCT AND EL PASO COUNTY PARKS WHICH RETAINS ALL COMMON LAW, STATUTORY AND OTHER RESERVED RIGHTS, INCLUDING THE COPYRIGHT.

General Notes

No.	Revision/Issue	Date

Firm Name and Address
EL PASO COUNTY PARKS
 2002 CREEK CROSSING
 COLORADO SPRINGS, CO 80905

Project Name and Address
ADA ACCESSIBILITY IMPROVEMENTS AT THE EL PASO COUNTY FAIRGROUNDS
 366 10TH STREET
 CALHAN, CO 80808

Project	Sheet
Date 03-04-2021	C-1
Scale 1:20	

1 LAYOUT PLAN - AREA 1

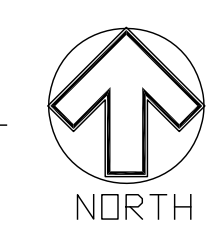

THIS DOCUMENT AND ITS CONTENTS ARE THE WORK PRODUCT AND EL PASO COUNTY PARKS WHICH RETAINS ALL COMMON LAW, STATUTORY AND OTHER RESERVED RIGHTS, INCLUDING THE COPYRIGHT.

General Notes

OWENS LIVESTOCK ARENA

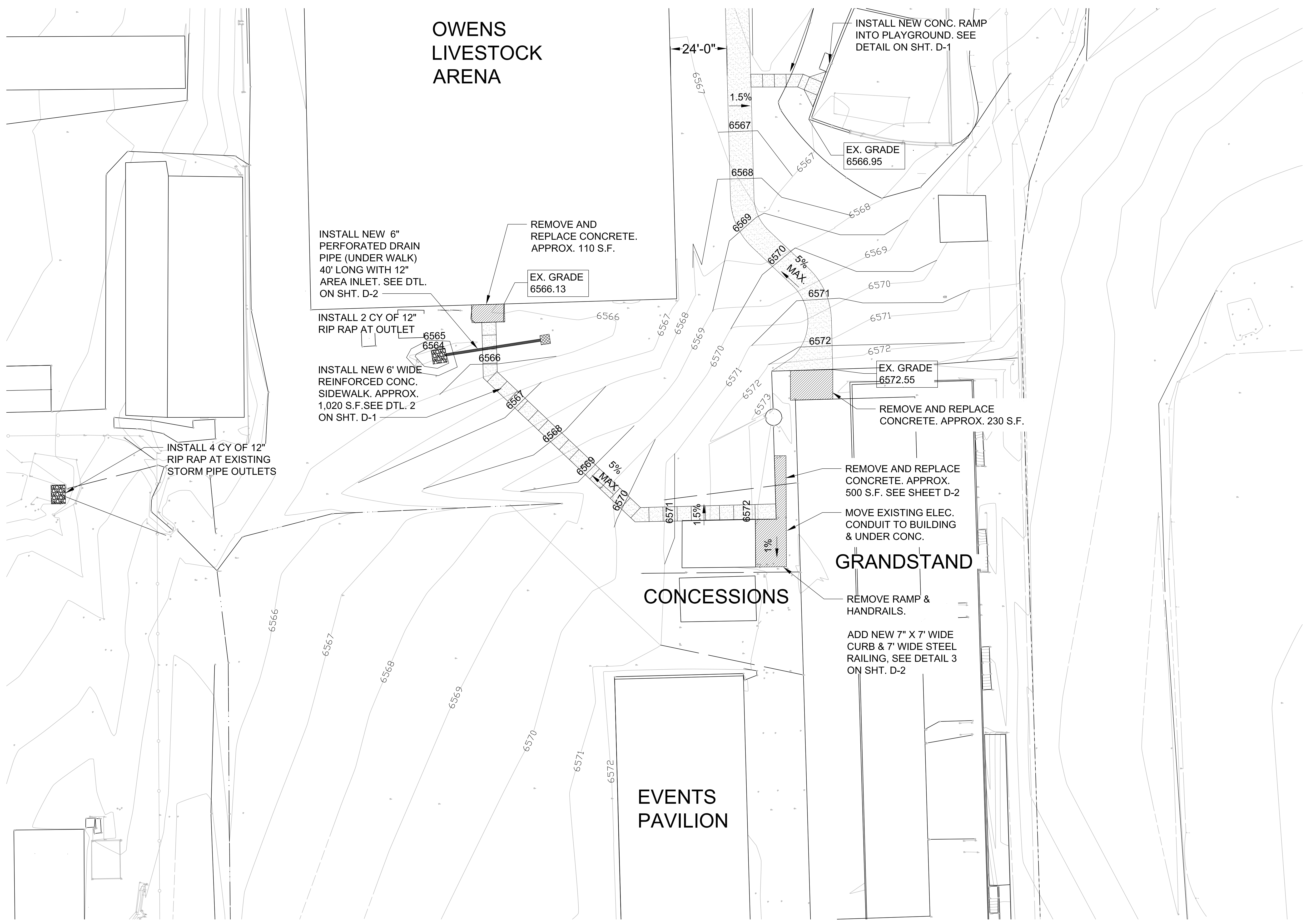

INSTALL NEW 6" PERFORATED DRAIN PIPE (UNDER WALK) 40' LONG WITH 12" AREA INLET. SEE DTL. ON SHT. D-2

REMOVE AND REPLACE CONCRETE. APPROX. 110 S.F.

EX. GRADE 6566.13

INSTALL 2 CY OF 12" RIP RAP AT OUTLET

INSTALL NEW 6' WIDE REINFORCED CONC. SIDEWALK. APPROX. 1,020 S.F. SEE DTL. 2 ON SHT. D-1

INSTALL 4 CY OF 12" RIP RAP AT EXISTING STORM PIPE OUTLETS

INSTALL NEW CONC. RAMP INTO PLAYGROUND. SEE DETAIL ON SHT. D-1

EX. GRADE 6566.95

EX. GRADE 6572.55

REMOVE AND REPLACE CONCRETE. APPROX. 230 S.F.

REMOVE AND REPLACE CONCRETE. APPROX. 500 S.F. SEE SHEET D-2

MOVE EXISTING ELEC. CONDUIT TO BUILDING & UNDER CONC.

GRANDSTAND

REMOVE RAMP & HANDRAILS.

ADD NEW 7" X 7' WIDE CURB & 7' WIDE STEEL RAILING. SEE DETAIL 3 ON SHT. D-2

CONCESSIONS

EVENTS PAVILION

1 LAYOUT PLAN - AREA 2

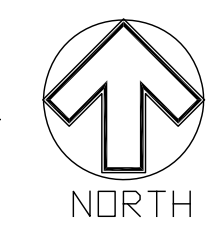

No.	Revision/Issue	Date

Firm Name and Address
EL PASO COUNTY PARKS
 2002 CREEK CROSSING
 COLORADO SPRINGS, CO 80905

Project Name and Address
ADA ACCESSIBILITY IMPROVEMENTS AT THE EL PASO COUNTY FAIRGROUNDS
 366 10TH STREET
 CALHAN, CO 80808

Project	Sheet
Date 03-04-2021	C-2
Scale 1:20	

USER REVDATE FNAME

THIS DOCUMENT AND ITS CONTENTS ARE THE WORK PRODUCT AND EL PASO COUNTY PARKS WHICH RETAINS ALL COMMON LAW, STATUTORY AND OTHER RESERVED RIGHTS, INCLUDING THE COPYRIGHT.

General Notes

No.	Revision/Issue	Date

Firm Name and Address
EL PASO COUNTY PARKS
 2002 CREEK CROSSING
 COLORADO SPRINGS, CO 80905

Project Name and Address
ADA ACCESSIBILITY IMPROVEMENTS AT THE EL PASO COUNTY FAIRGROUNDS
 366 10TH STREET
 CALHAN, CO 80808

Project	Sheet
Date 03-04-2021	C-3
Scale 1:20	

SWINK HALL

LIVESTOCK PAVILION

OWENS LIVESTOCK ARENA

INSTALL NEW 6' WIDE REINFORCED CONC. SIDEWALK. APPROX. 653 S.F. SEE DTL. 2 ON SHT. D-1

EX. GRADE 6564.13

INSTALL NEW 10' WIDE ASPHALT WALK. APPROX. 4,380 S.F. SEE DTL. 1 SHT. D-1

INSTALL NEW 6' WIDE REINFORCED CONC. APPROX. 200 S.F. SIDEWALK. SEE DTL. 2 ON SHT. D-1

INSTALL NEW CONC. RAMP INTO PLAYGROUND. SEE DETAIL ON SHT. D-1

EX. GRADE 6566.95

INSTALL NEW 6" PERFORATED DRAIN

REMOVE AND REPLACE CONCRETE. APPROX. 110 S.F.

1 LAYOUT PLAN - AREA 3

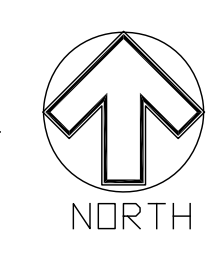

FNAME
REVDATE
USER

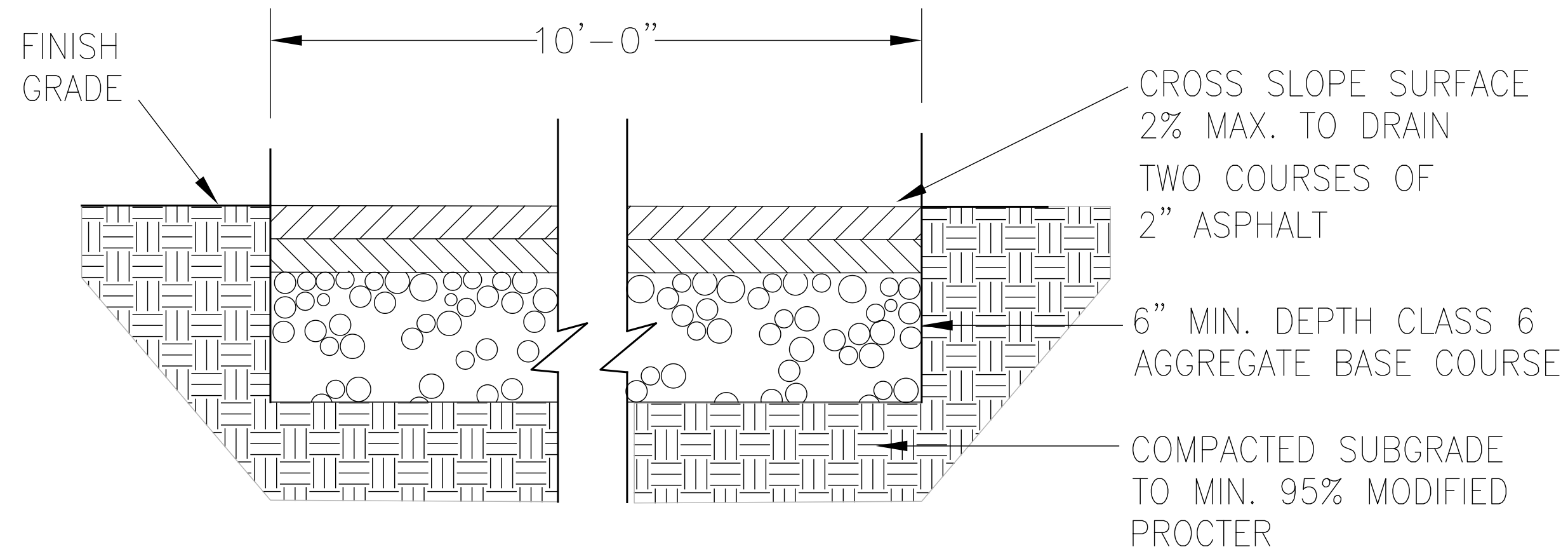

1 ASPHALT DETAIL

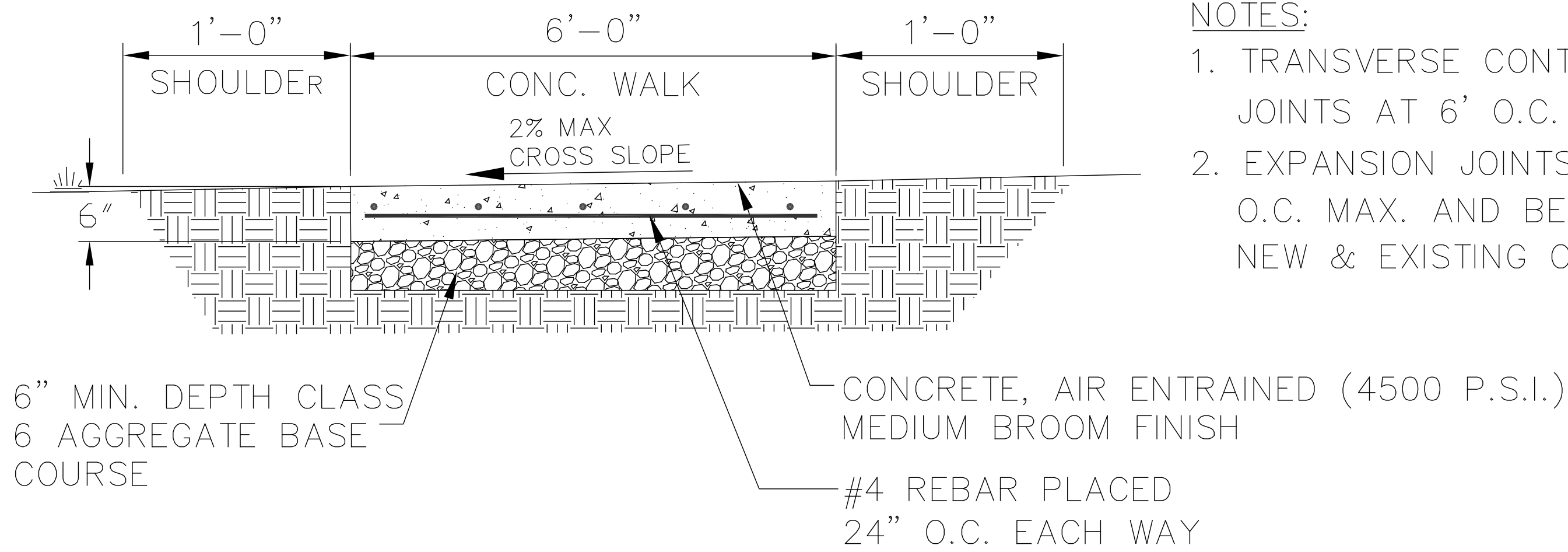

- NOTES:
1. TRANSVERSE CONTRACTION JOINTS AT 6' O.C. MAX
 2. EXPANSION JOINTS AT 25' O.C. MAX. AND BETWEEN NEW & EXISTING CONCRETE

2 CONC. SIDEWALK DETAIL

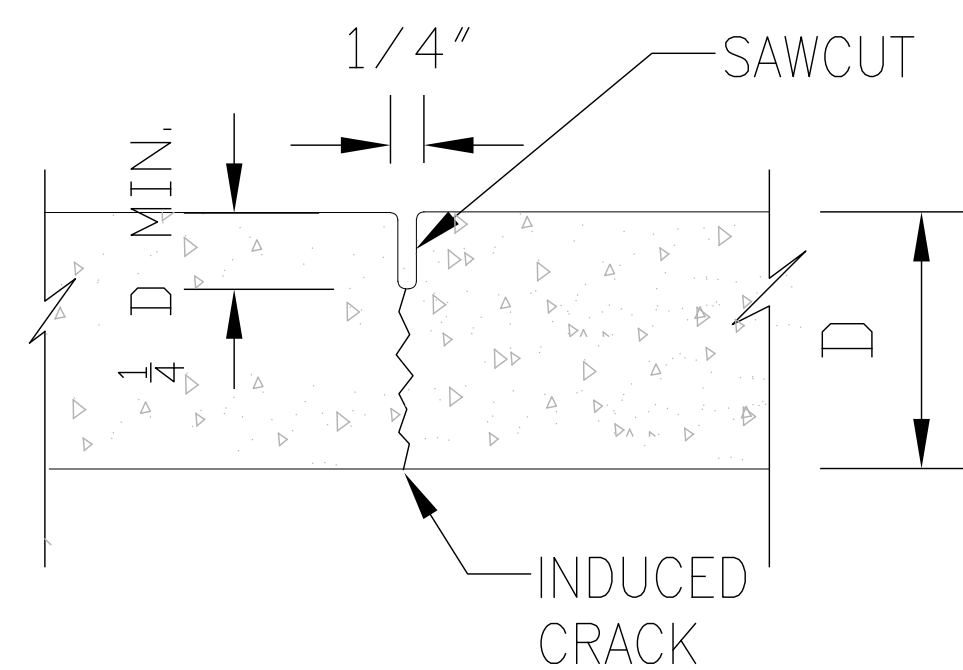

CONTRACTION JOINT

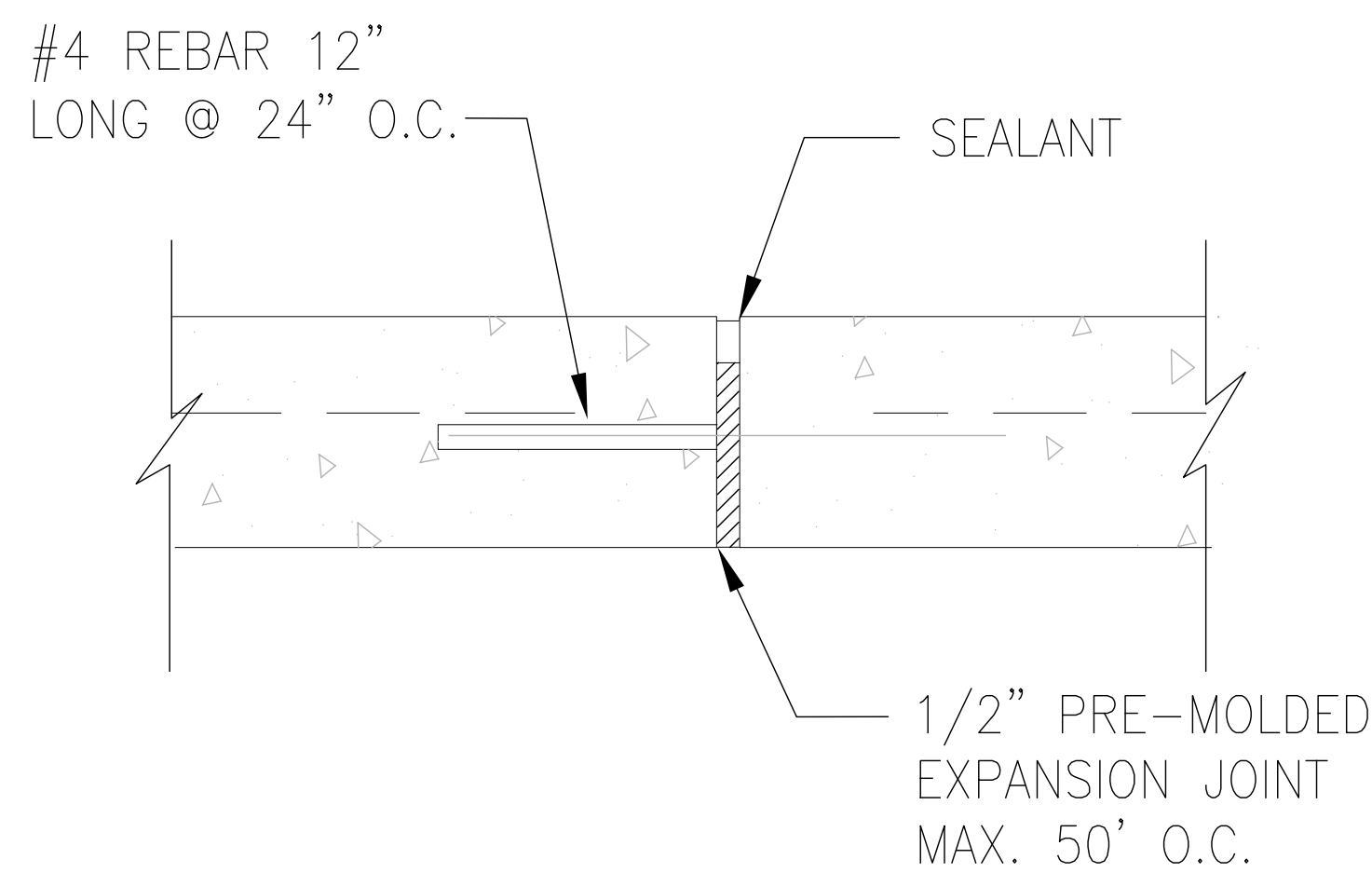

EXPANSION JOINT

3 CONCRETE JOINTS DETAIL

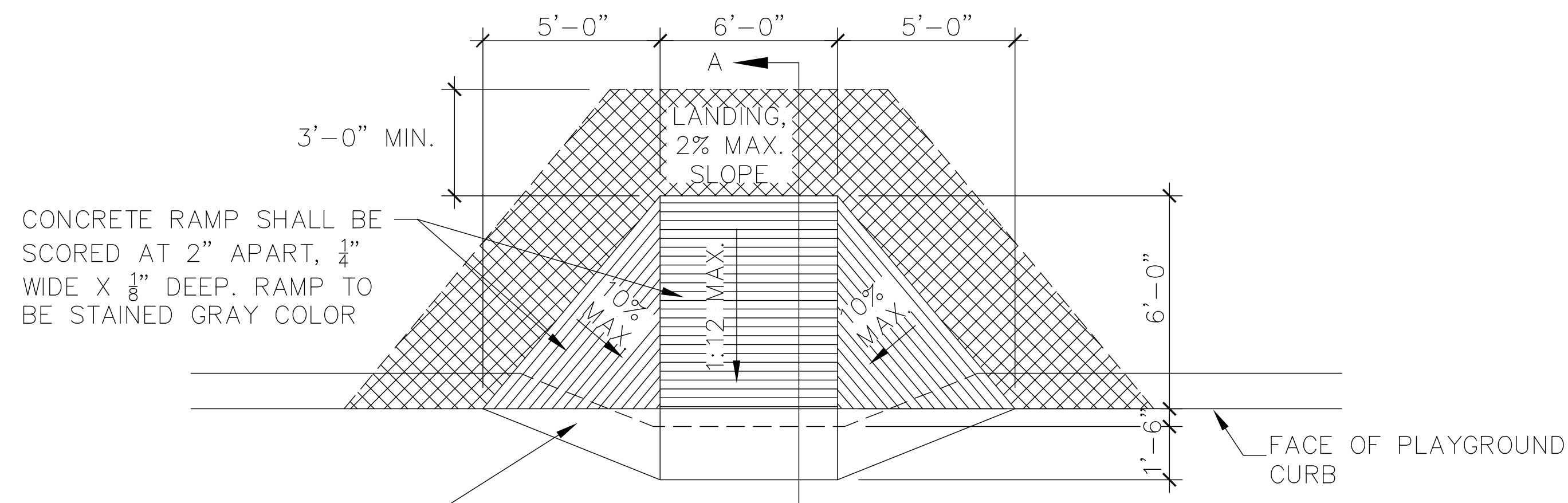

RAMP - PLAN

SCALE: 1/4" = 1'-0"

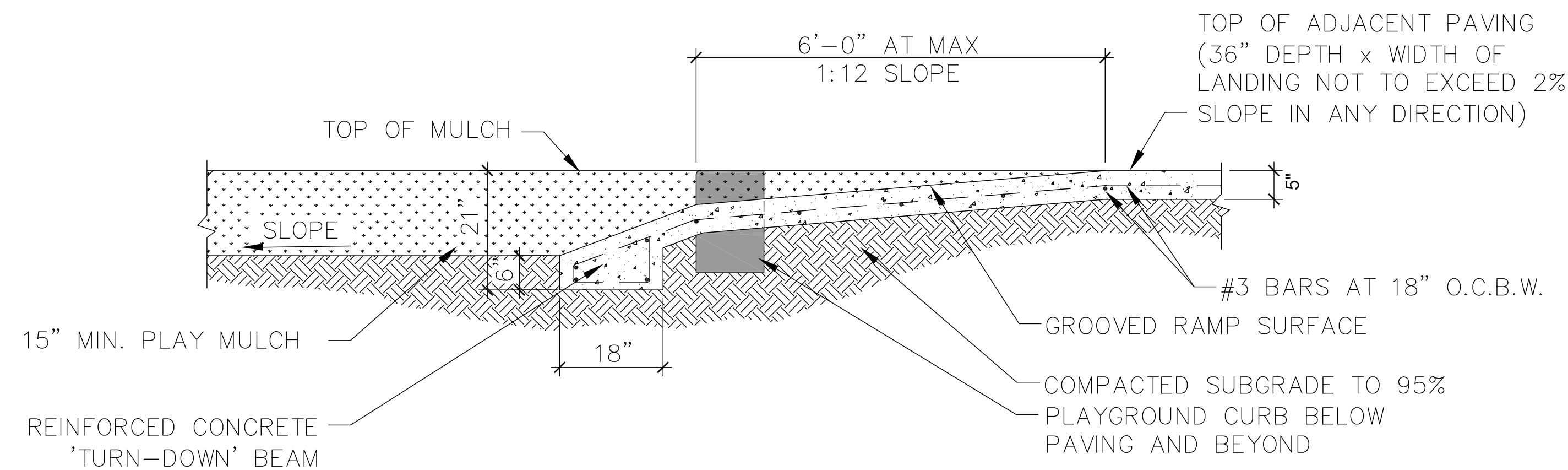

RAMP - SECTION

SCALE: 1/2" = 1'-0"

4 CONC. RAMP AT PLAYGROUND

THIS DOCUMENT AND ITS CONTENTS ARE THE WORK PRODUCT AND EL PASO COUNTY PARKS WHICH RETAINS ALL COMMON LAW, STATUTORY AND OTHER RESERVED RIGHTS, INCLUDING THE COPYRIGHT.

General Notes

No.	Revision/Issue	Date

Firm Name and Address
EL PASO COUNTY PARKS
 2002 CREEK CROSSING
 COLORADO SPRINGS, CO 80905

Project Name and Address
**ADA ACCESSIBILITY
 IMPROVEMENTS AT THE EL PASO
 COUNTY FAIRGROUNDS**
 366 10TH STREET
 CALHAN, CO 80808

Project	Sheet
Date 03-04-2021	D-1
Scale	



1 REPLACE CONCRETE VIEW 1



2 REPLACE CONCRETE VIEW 2



3 REMOVE RAMP & HANDRAILS

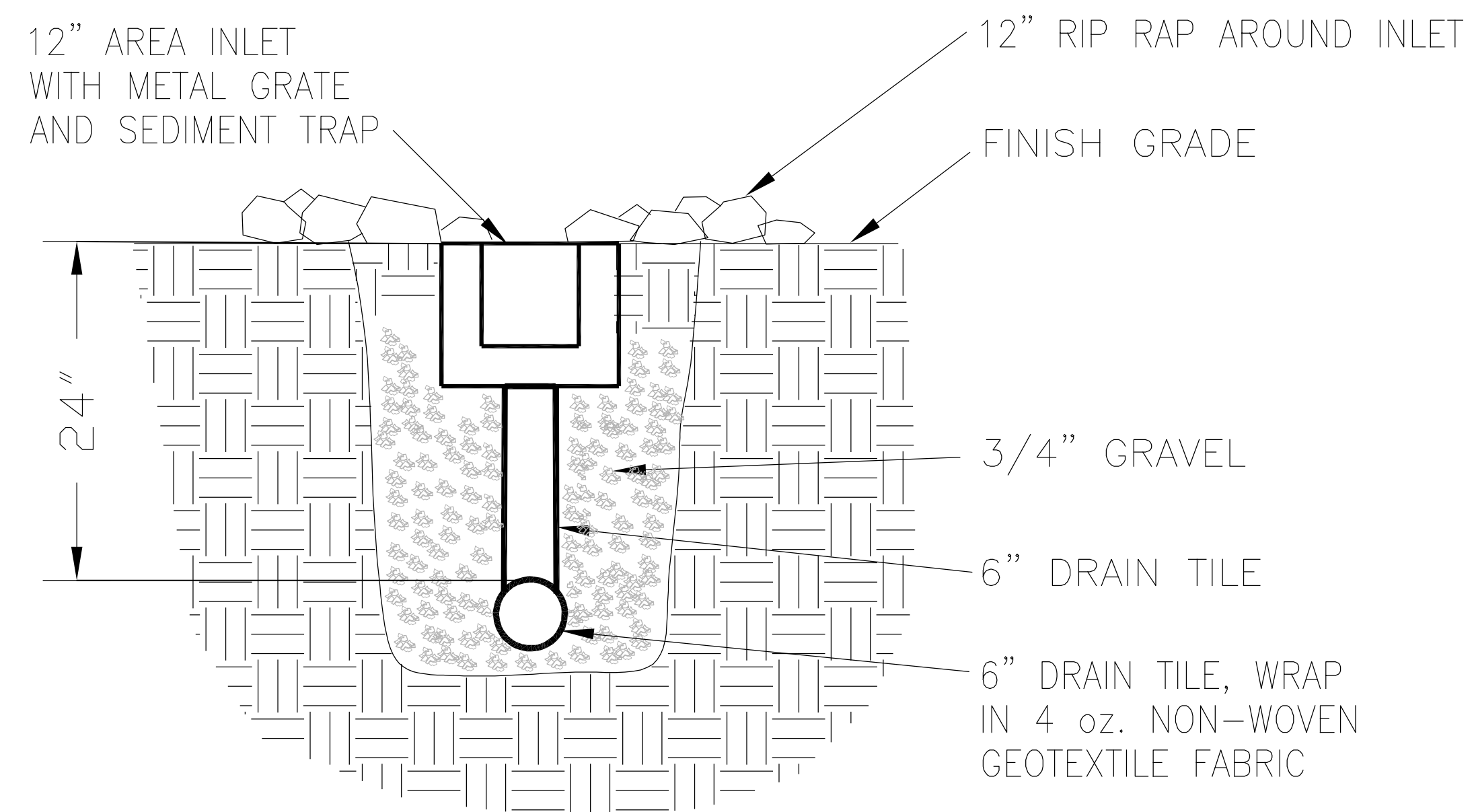

4 AREA INLET AND PERF. PIPE

THIS DOCUMENT AND ITS CONTENTS ARE THE WORK PRODUCT AND EL PASO COUNTY PARKS WHICH RETAINS ALL COMMON LAW, STATUTORY AND OTHER RESERVED RIGHTS, INCLUDING THE COPYRIGHT.

General Notes

No.	Revision/Issue	Date

Firm Name and Address
EL PASO COUNTY PARKS
 2002 CREEK CROSSING
 COLORADO SPRINGS, CO 80905

Project Name and Address
ADA ACCESSIBILITY IMPROVEMENTS AT THE EL PASO COUNTY FAIRGROUNDS
 366 10TH STREET
 CALHAN, CO 80808

Project	Sheet
Date 03-04-2021	D-2
Scale	